



868 MURRAY ROAD, DOTHAN, AL 36303

"REDIFLEX" TWO-PIECE STEEL FRAME SYSTEM UTILIZING A JELD-WEN DOUBLE OPAQUE STEEL DOOR "IMPACT"

GENERAL NOTES

1. This product has been evaluated and is in compliance with the 7th Edition (2020) Florida Building Code (FBC) structural requirements including the "High Velocity Hurricane Zone" (HVHZ).
2. Product anchors shall be as listed and spaced as shown on details. Anchor embedment to base material shall be beyond wall dressing or stucco.
3. When used in the "HVHZ" this product complies with Section 1626 of the FBC and does not require an impact resistant covering.
4. When used in areas outside of the "HVHZ" requiring wind borne debris protection this product complies with FBC Sections 1609.1.2 & R301.2.1.2 and does not require an impact resistant covering. This product meets missile level "D" and includes Wind Zone 4 as defined in ASTM E1996 and FBC Sections 1609.1.2.2 & R301.2.1.2.1.
5. For 2x stud framing construction, anchoring of these units shall be the same as that shown for 2x buck masonry construction.
6. Site conditions that deviate from the details of this drawing require further engineering analysis by a licensed engineer or registered architect.
7. Outswing configurations using item #72 meet water infiltration requirements for "HVHZ".
8. Configurations using item #70 and #71 do not meet the water infiltration requirements for the "HVHZ" and shall be installed only in non-habitable areas or at habitable locations protected by an overhang or canopy such that the angle between the edge of canopy or overhang to sill is less than 45 degrees.
9. When used in the "HVHZ, all steel shall be protected as specified in Section 2222.6 of the FBC.

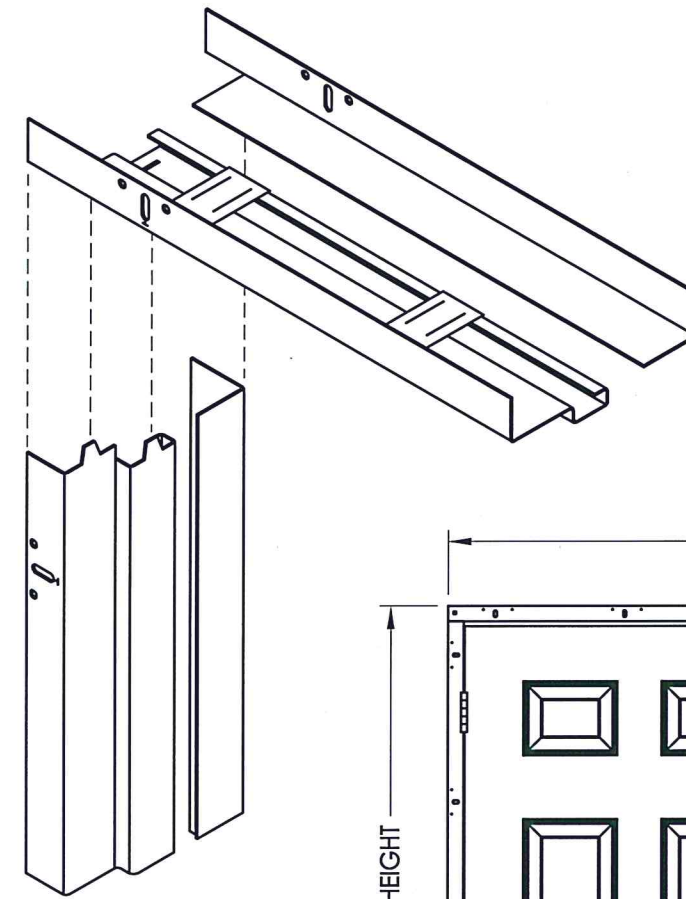

REDIFLEX TWO-PIECE

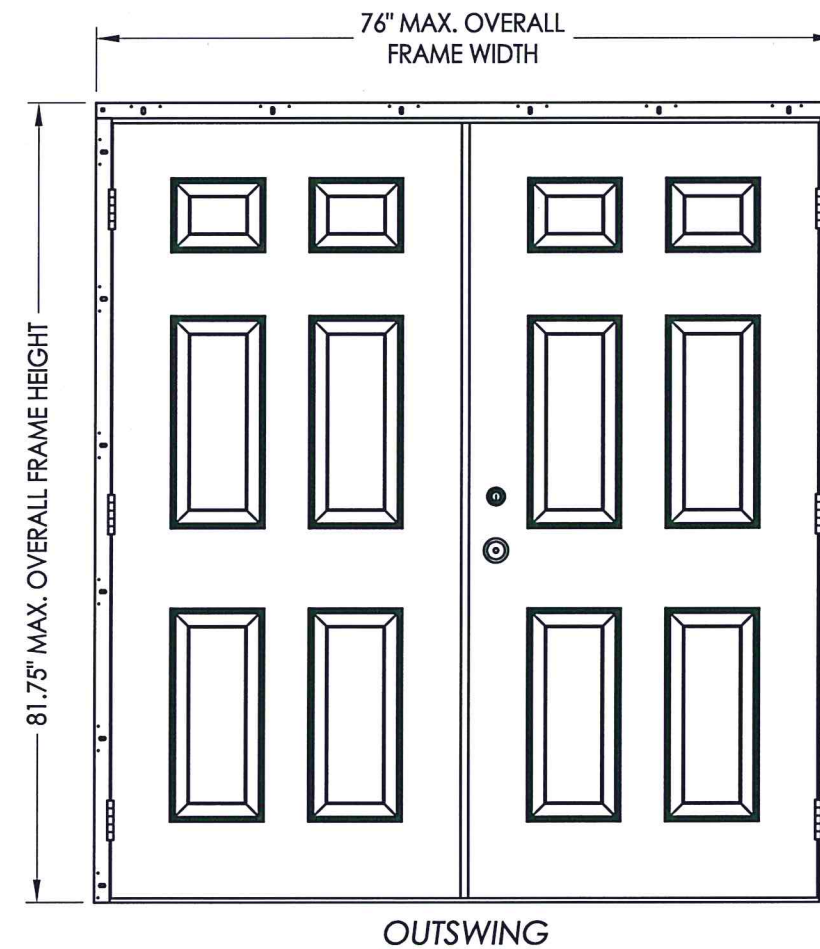

OUTSWING

TABLE OF CONTENTS	
SHEET #	DESCRIPTION
1	Typical elevation, design pressures & general notes
2	Steel frame cross sections & details
3	Door panel details
4	Horizontal & vertical cross sections
5	Horizontal & vertical cross sections
6	Buck & frame anchoring - masonry 2x buck
7	Buck & frame anchoring - steel/2x stud
8	Astragal details
9	Bill of materials and components

OVERALL FRAME DIMENSION	THRESHOLD TYPE	DESIGN PRESSURE (PSF) NON-HVHZ		DESIGN PRESSURE (PSF) HVHZ	
		POSITIVE	NEGATIVE	POSITIVE	NEGATIVE
76.0" X 81.75"	ADA	+ 55.0	- 55.0	+ 55.0*	- 55.0*
76.0" X 81.75"	STANDARD BUMP	+ 55.0	- 55.0	+ 50.0	- 50.0
76.0" X 81.75"	HIGH DAM	+ 55.0	- 55.0	+ 55.0	- 55.0

*See General Note #8

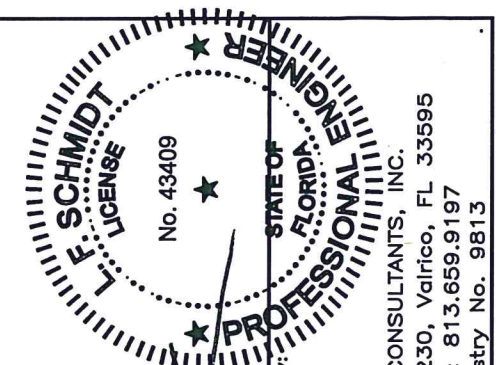

August 11, 2020
Documents Prepared By:
Lyndon F. Schmidt
P.E. No. 43409

RW BUILDING CONSULTANTS, INC.
P.O. Box 230, Vairico, FL 33595
Phone No.: 813.659.9197
FBPE Registry No. 9813

PRODUCT:
DUNBARTON REDIFLEX
TWO-PIECE STEEL FRAME
PART OR ASSEMBLY:
TYPICAL ELEVATION, DESIGN
PRESSURES & GENERAL NOTES

NO.	DATE	REVISIONS
3	8/11/20	UPDATE TO 7TH ED. (2020) FBC
2	9/30/17	UPDATE TO 6TH ED. (2017) FBC
1	3/23/15	UPDATE TO 5TH ED. (2014) FBC

DATE: 6/3/13
SCALE: N.T.S.
DWG. BY: JK
CHK. BY: LFS
DRAWING NO.:
FL-15341.8
SHEET 1 OF 9

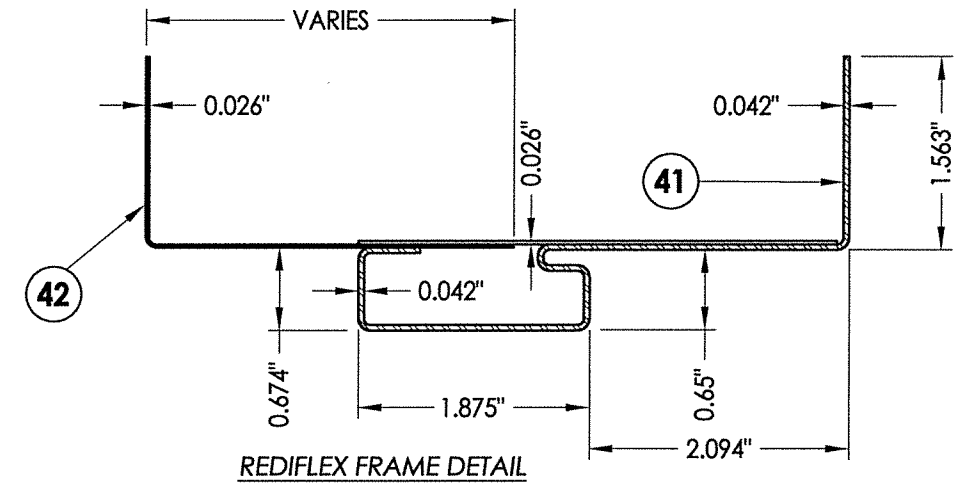
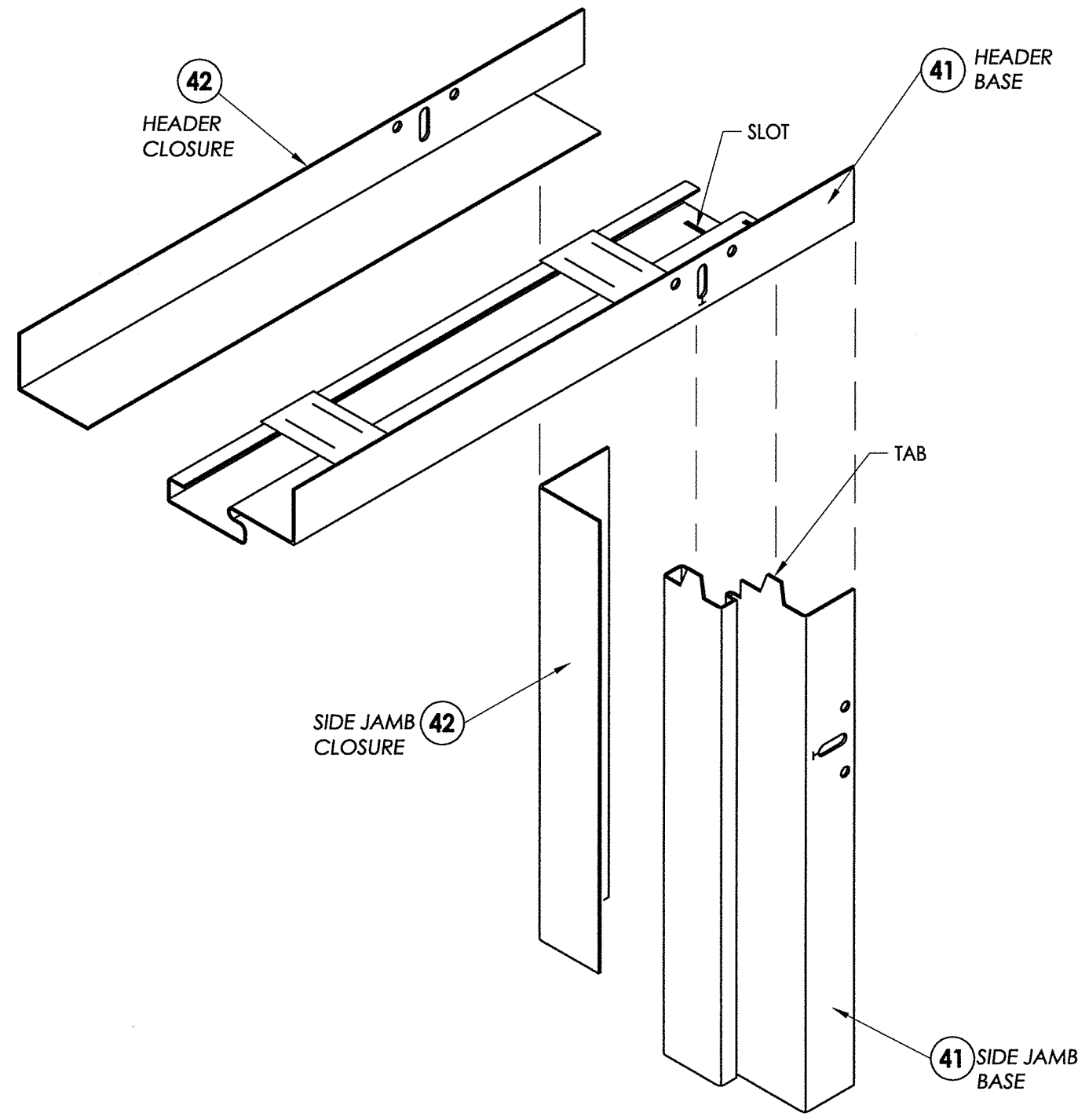

- NOTES:**
1. HEADER AND SIDE BASE JAMB (41) MINIMUM 18 GA. GALV. STEEL.
 2. HEADER AND SIDE CLOSURE JAMB (42) MINIMUM 22 GA. GALV. STEEL.
 3. FRAME SHOWN WITHOUT OPTIONAL STEEL TRIM CASING.
 4. NON-KERF FRAMES DO NOT MEET AIR AND WATER CRITERIA.

August 11, 2020
 Documents Prepared By:
 Lyndon F. Schmidt
 P.E. No. 43409

R.W.
 BUILDING CONSULTANTS, INC.
 P.O. Box 230, Valrico, FL 33595
 Phone No.: 813.659.9197
 FBPE Registry No. 9813

PRODUCT: DUNBARTON REDIFLEX TWO-PIECE STEEL FRAME	
PART OR ASSEMBLY: STEEL FRAME CROSS SECTION & DETAILS	
REVISIONS	
NO.	DATE
3	8/11/20 UPDATE TO 7TH ED. (2020) FBC DAC
2	9/30/17 UPDATE TO 6TH ED. (2017) FBC LFS
1	3/23/15 UPDATE TO 5TH ED. (2014) FBC JK
DATE: 6/3/13	
SCALE: N.T.S.	
DWG. BY: JK	
CHK. BY: LFS	
DRAWING NO.: FL-15341.8	
SHEET 2 OF 9	

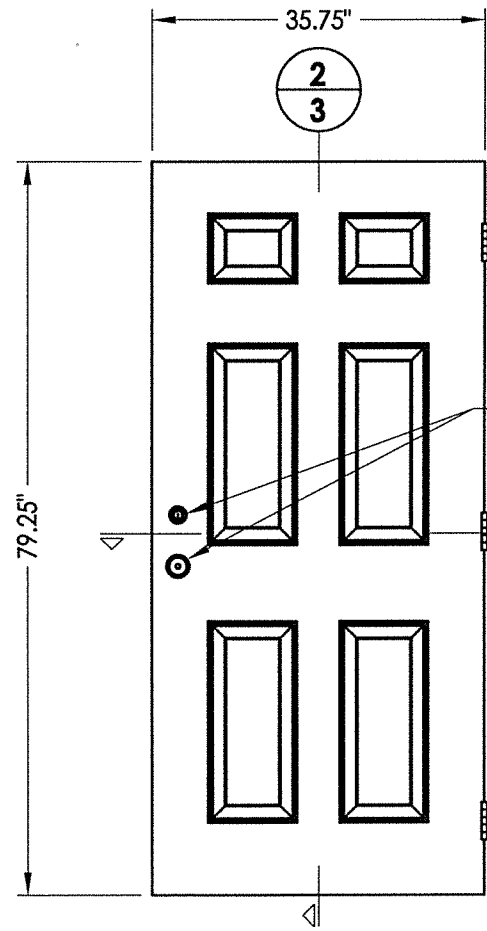
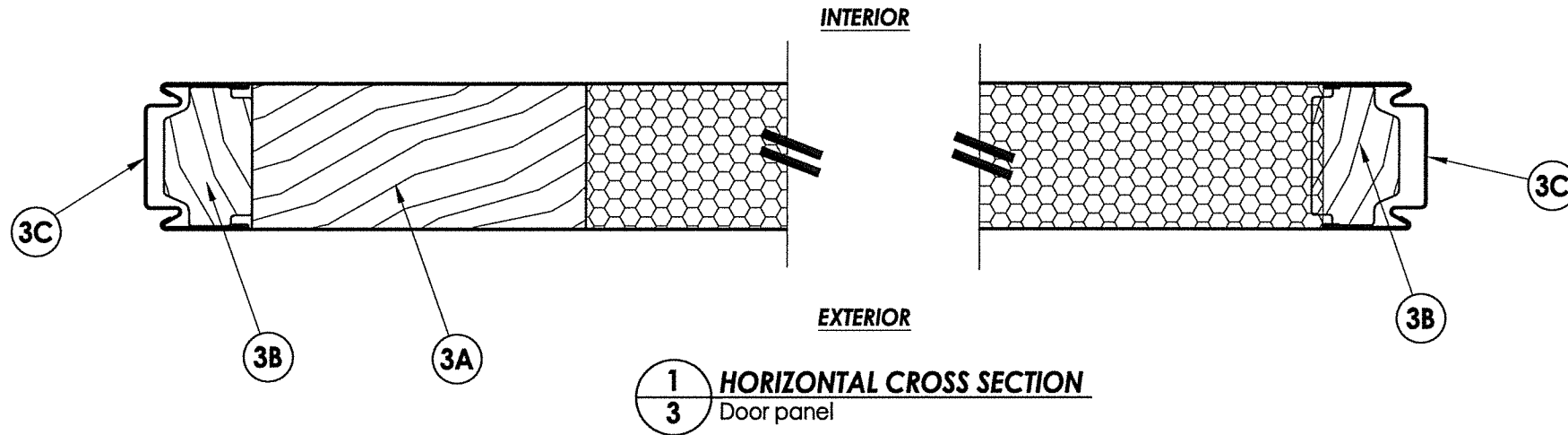

50 **DOOR PANEL**
JELD-WEN

STEEL SKIN: 0.020" MIN. THICK (Fy = 30,100 PSI MIN.)
FOAM CORE: POLYSTYRENE (1.25 PCF DENSITY)

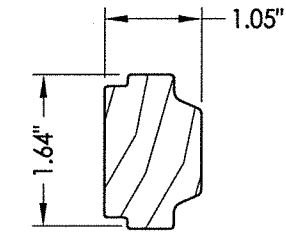

3B **STILE**
Reinforcement

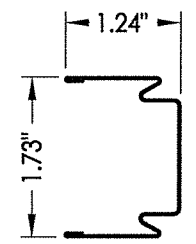

3C **LATCH / HINGE STILE**
& Top rail

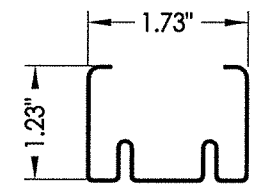

3D **BOTTOM RAIL**
Steel edge door

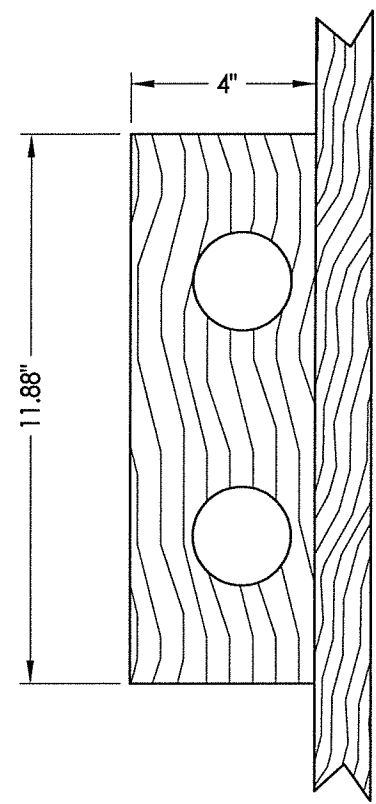

3A **LOCK BLOCK**

HARDWARE CHART	
MANUFACTURER	MODEL
KWIKSET	LEVER: 200DL
	DEADBOLT: Signature Series 980
SCHLAGE	LOCK: F51
	DEADBOLT: B60N

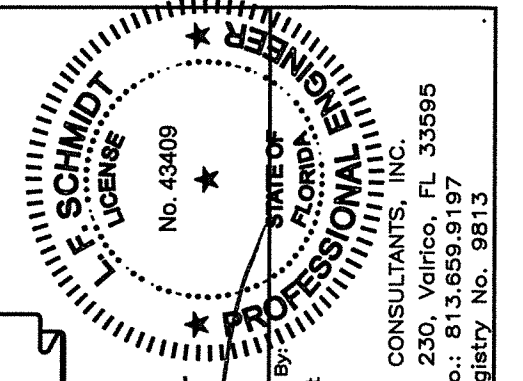
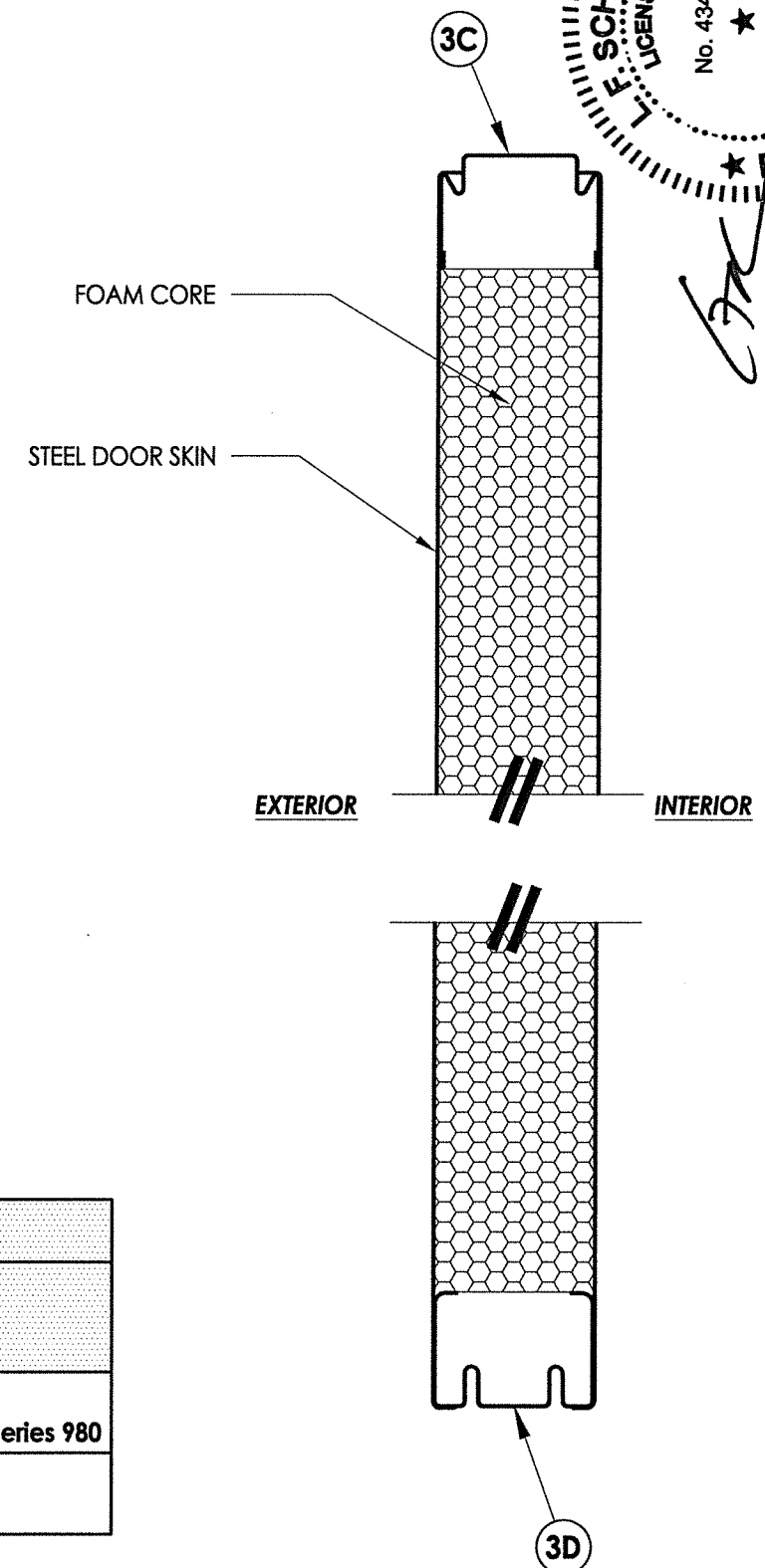

August 11, 2020
Documents Prepared By:
Lyndon F. Schmidt
P.E. No. 43409
R.W.
BUILDING CONSULTANTS, INC.
P.O. Box 230, Valrico, FL 33595
Phone No.: 813.659.9197
FBPE Registry No. 9813

PRODUCT:		DUNBARTON REDIFLEX	
		TWO-PIECE STEEL FRAME	
PART OR ASSEMBLY:		DOOR PANEL DETAILS	
		DAC	
3	8/11/20	UPDATE TO 7TH ED. (2020)	FBC
2	9/30/17	UPDATE TO 6TH ED. (2017)	FBC
1	3/23/15	UPDATE TO 5TH ED. (2014)	FBC
NO.	DATE	JK	BY
REVISIONS			
DATE:		6/3/13	
SCALE:		N.T.S.	
DWG. BY:		JK	
CHK. BY:		LFS	
DRAWING NO.:		FL-15341.8	
SHEET		3 of 9	

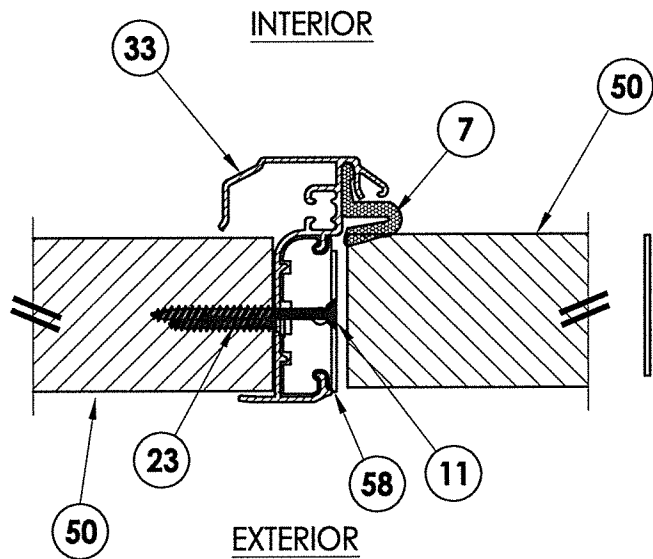
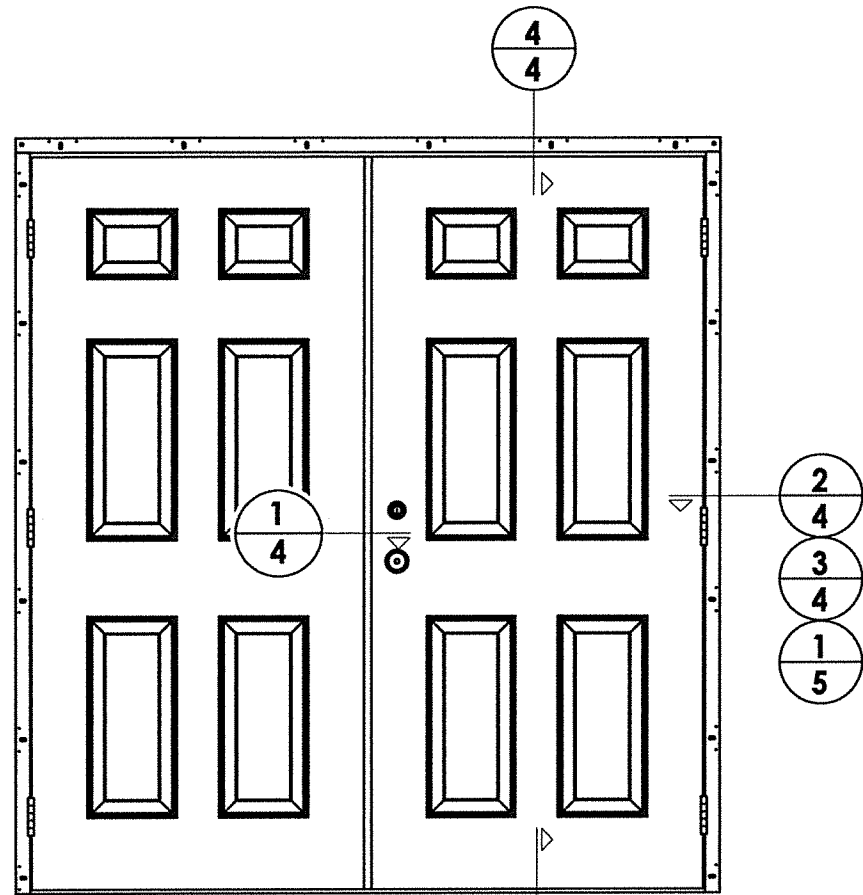

1
4 HORIZONTAL CROSS SECTION

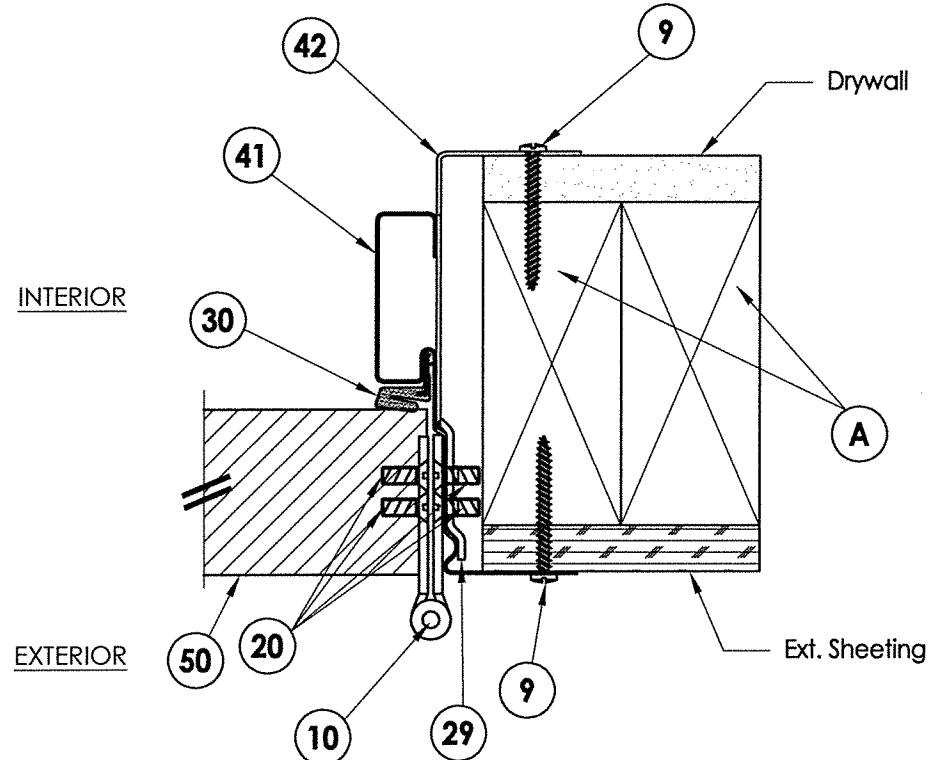

2
4 HORIZONTAL CROSS SECTION
Optional 2X Stud Construction

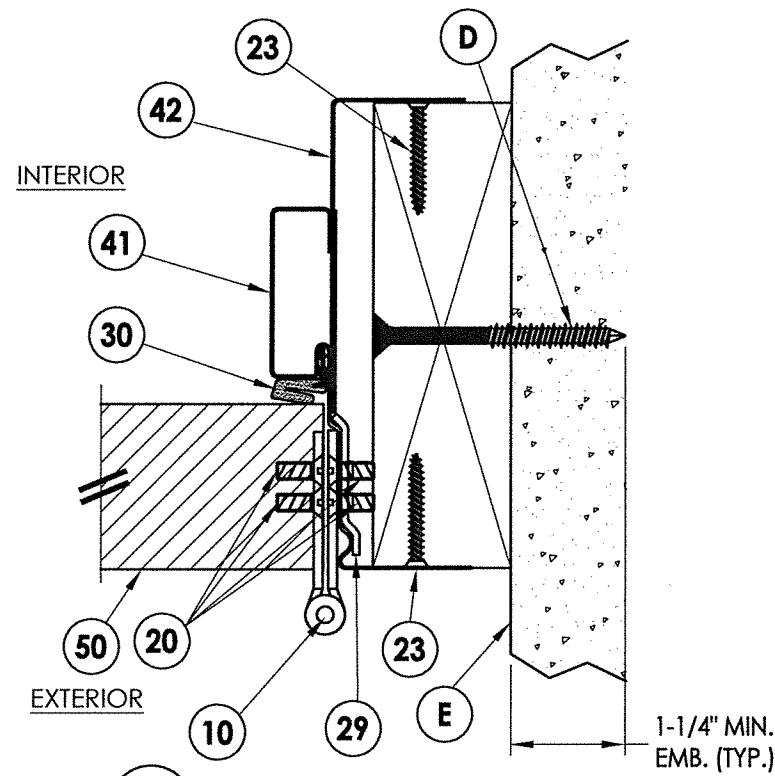

3
4 HORIZONTAL CROSS SECTION
2X wood buck

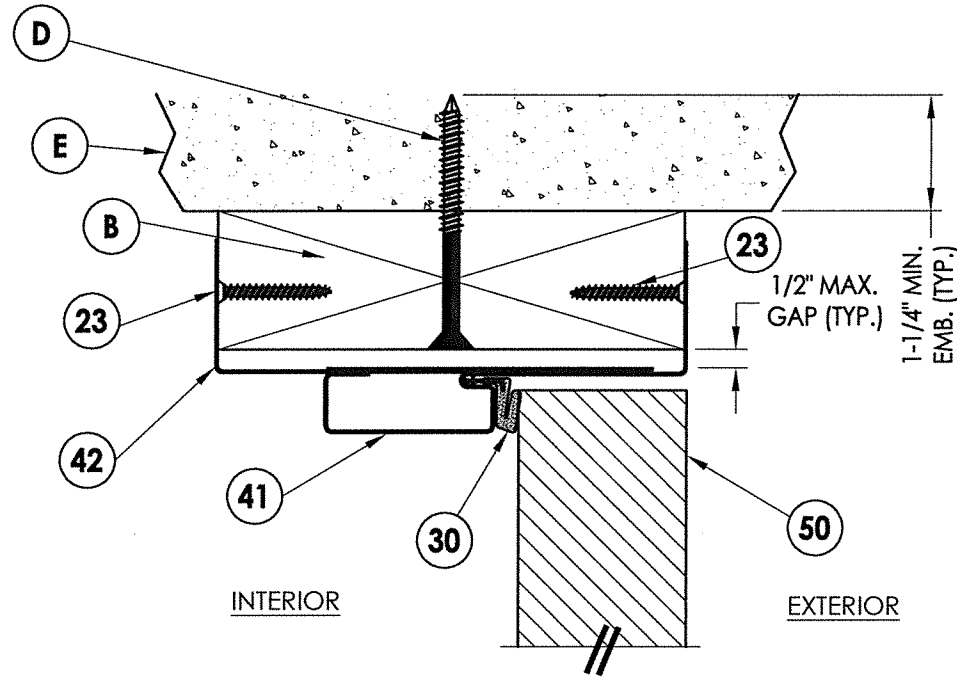

4
4 VERTICAL CROSS SECTION
2X wood buck

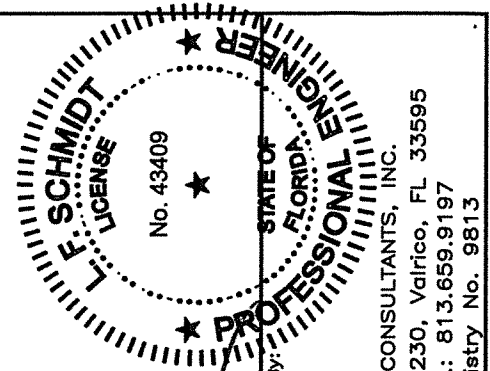

August 11, 2020
 Documents Prepared By:
 Lyndon F. Schmidt
 P.E. No. 43409
 R.W. BUILDING CONSULTANTS, INC.
 P.O. Box 230, Vairico, FL 33595
 Phone No.: 813.659.9197
 FBPE Registry No. 9813

PRODUCT:		DUNBARTON REDIFLEX TWO-PIECE STEEL FRAME	
PART OR ASSEMBLY:		HORIZONTAL & VERTICAL CROSS SECTIONS	
NO.	DATE	BY	REVISIONS
3	8/11/20	DAC	UPDATE TO 7TH ED. (2020) FBC
2	9/30/17	JFK	UPDATE TO 6TH ED. (2017) FBC
1	3/23/15	JFK	UPDATE TO 5TH ED. (2014) FBC
DATE: 6/3/13			
SCALE: N.T.S.			
DWG. BY: JK			
CHK. BY: LFS			
DRAWING NO.: FL-15341.8			
SHEET 4 OF 9			

Note:
1. A minimum of three threads must protrude completely through the supporting steel stud.

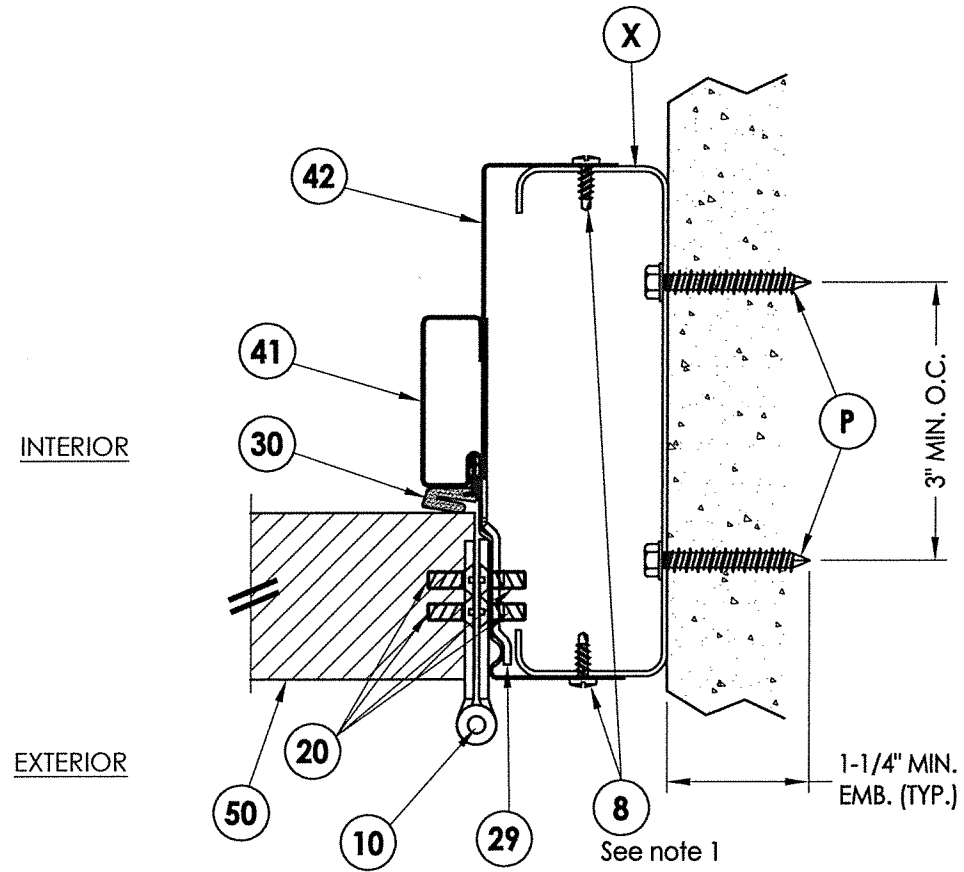

1 HORIZONTAL CROSS SECTION
5 Optional steel stud construction

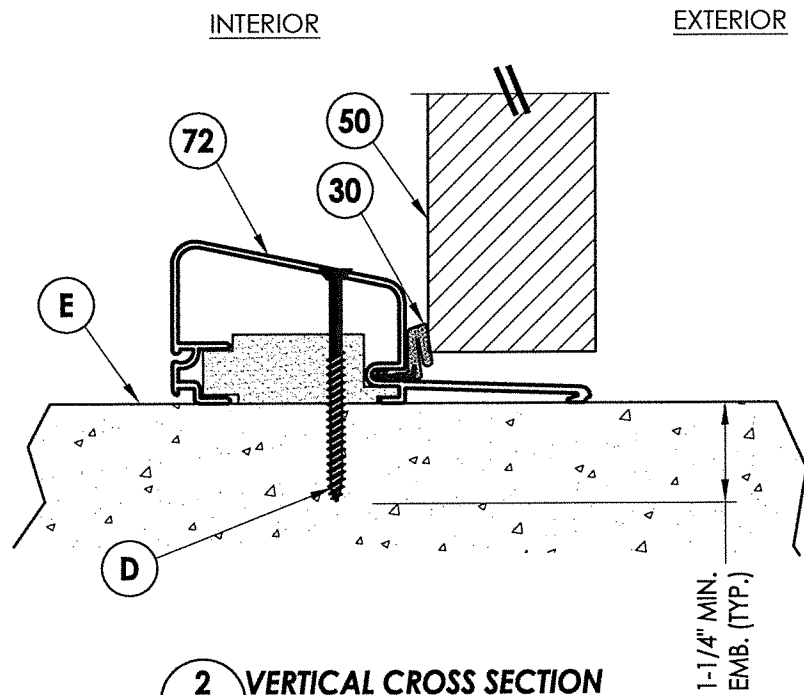

2 VERTICAL CROSS SECTION
5 Shown w/ High Dam Threshold

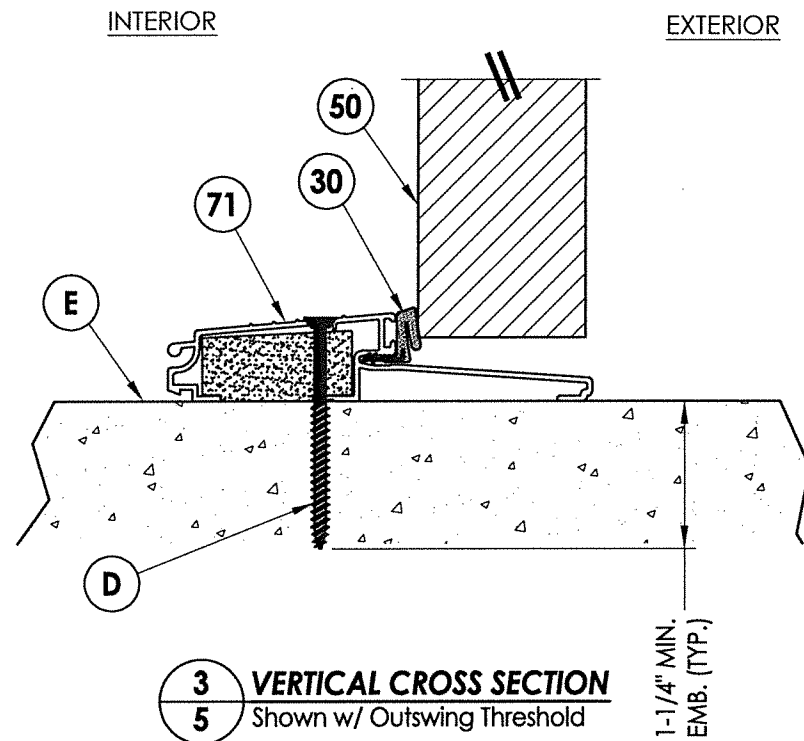

3 VERTICAL CROSS SECTION
5 Shown w/ Outswing Threshold

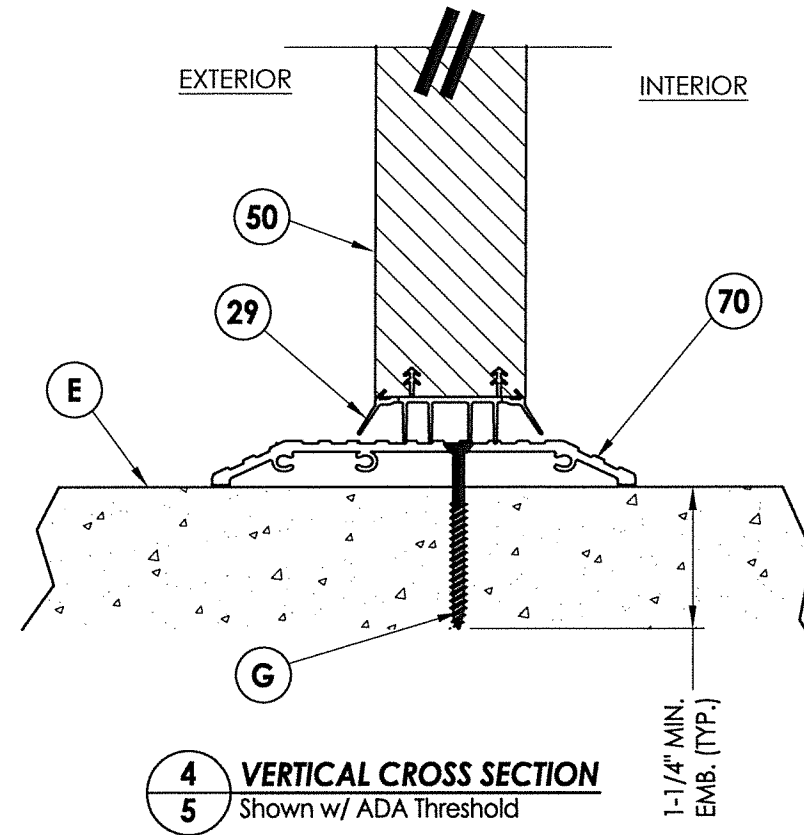

4 VERTICAL CROSS SECTION
5 Shown w/ ADA Threshold

August 11, 2020
 Documents Prepared By:
 Lyndon F. Schmidt
 P.E. No. 43409

R.W.
 BUILDING CONSULTANTS, INC.
 P.O. Box 230, Valrico, FL 33595
 Phone No.: 813.659.9197
 FBPE Registry No. 9813

PRODUCT:		DUNBARTON REDIFLEX TWO-PIECE STEEL FRAME	
PART OR ASSEMBLY:		HORIZONTAL & VERTICAL CROSS SECTIONS	
NO.	DATE	BY	REVISIONS
3	8/11/20	FBC DAC	UPDATE TO 7TH ED. (2020)
2	9/30/17	FBC LFS	UPDATE TO 6TH ED. (2017)
1	3/23/15	FBC JK	UPDATE TO 5TH ED. (2014)
DATE: 6/3/13			
SCALE: N.T.S.			
DWG. BY: JK			
CHK. BY: LFS			
DRAWING NO.: FL-15341.8			
SHEET 5 OF 9			

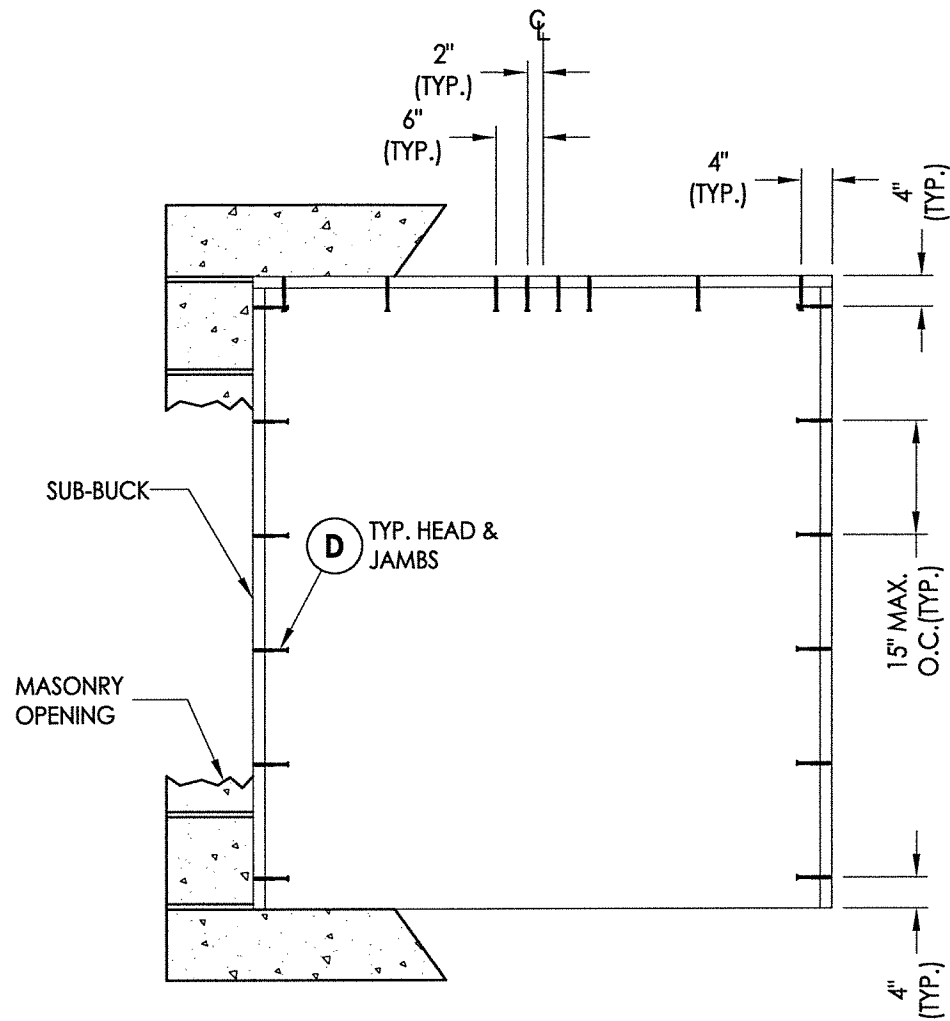

BUCK ANCHORING
Masonry 2X buck construction

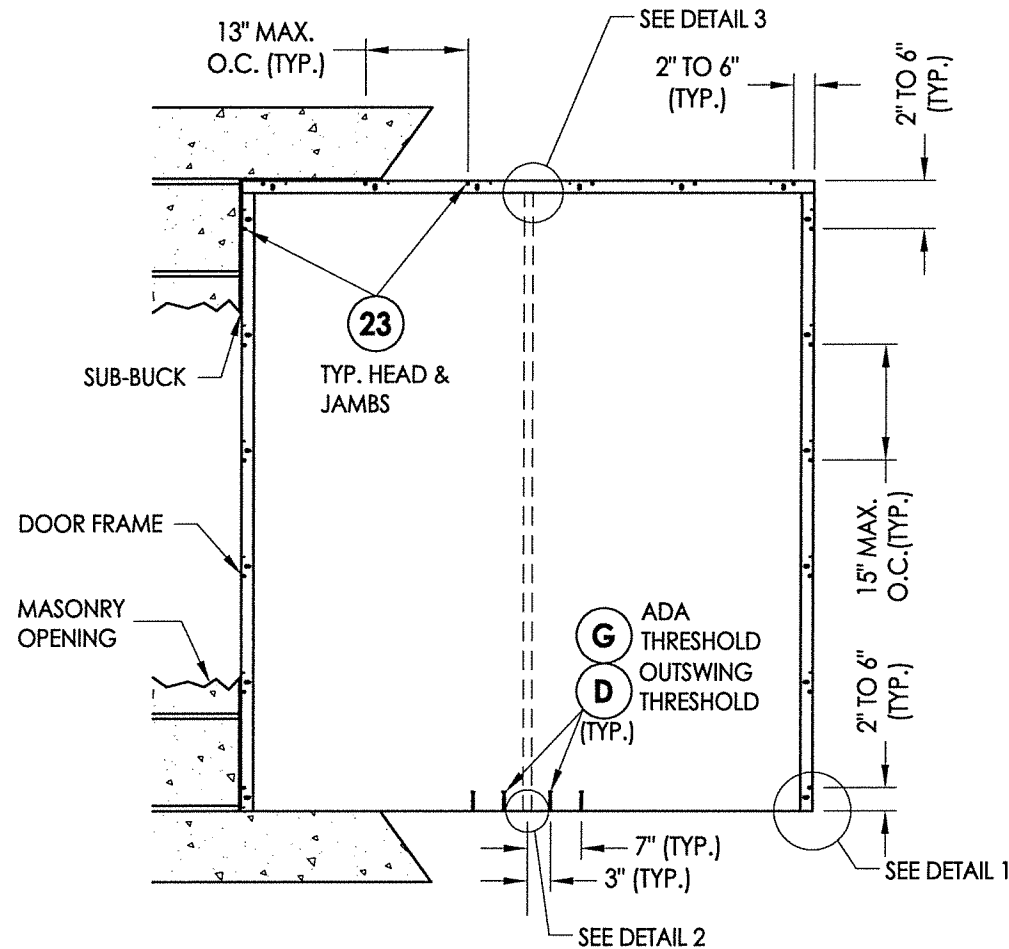

FRAME ANCHORING
Masonry 2X buck construction

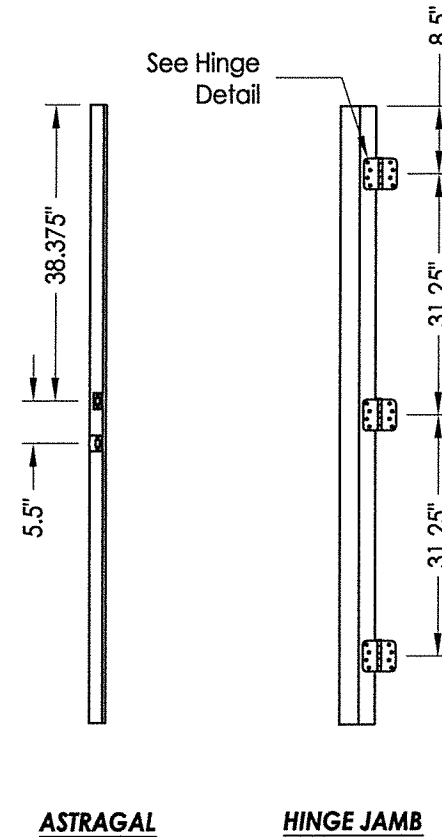

ASTRAGAL

HINGE JAMB

CONCRETE ANCHOR NOTES:

- Concrete anchor locations at the corners may be adjusted to maintain the min. edge distance to mortar joints.
- Concrete anchor locations noted as "MAX. ON CENTER" must be adjusted to maintain the min. edge distance to mortar joints, additional concrete anchors may be required to ensure the "MAX. ON CENTER" dimension are not exceeded.
- Concrete anchor table:

ANCHOR TYPE	ANCHOR SIZE	MIN. EMBEDMENT	MIN. CLEARANCE TO MASONRY EDGE	MIN. CLEARANCE TO ADJACENT ANCHOR
ITW TAPCON®	1/4"	1-1/4"	2"	4"
DeWALT ULTRACON+®	1/4"	1-1/4"	1"	4"

WOOD SCREW INSTALLATION NOTES:

- Maintain a minimum 5/8" edge distance, 1" end distance, & 1" o.c. spacing of wood screws to prevent the splitting of wood.

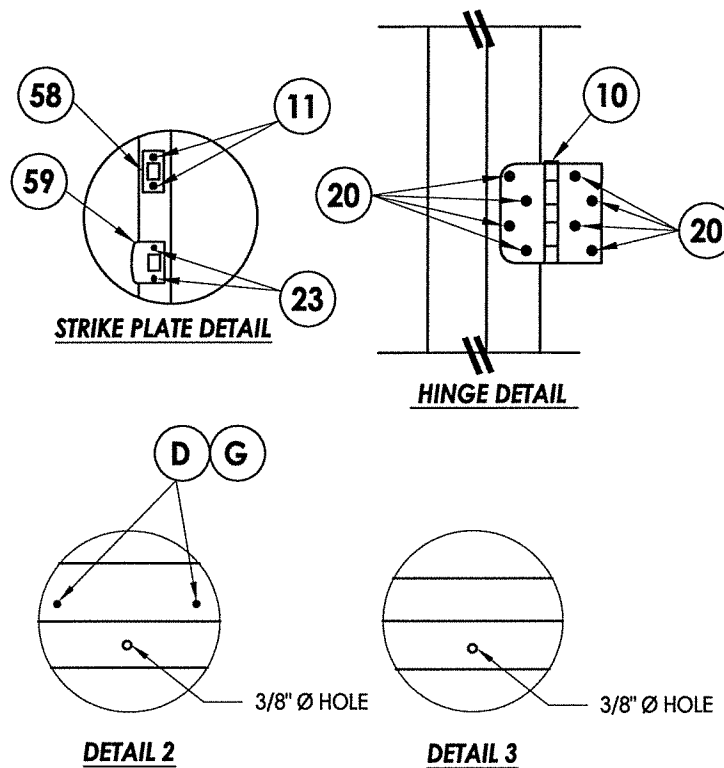

DETAIL 2

DETAIL 3

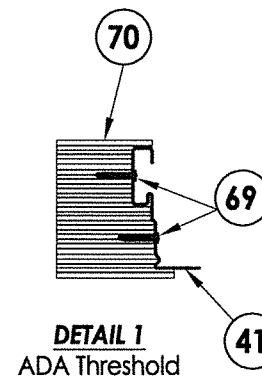

DETAIL 1
ADA Threshold

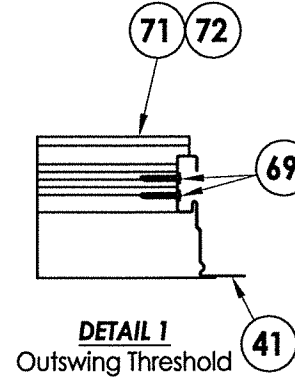

DETAIL 1
Outswing Threshold

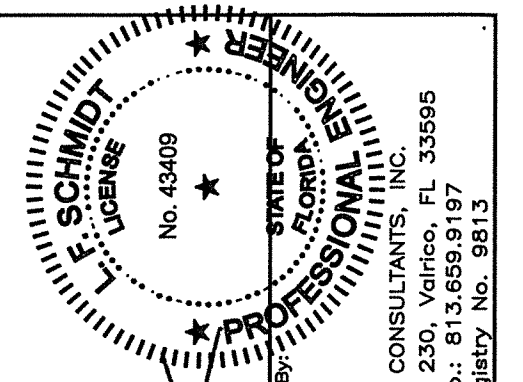

August 11, 2020
 Documents Prepared By:
 Lyndon F. Schmidt
 P.E. No. 43409
 BUILDING CONSULTANTS, INC.
 P.O. Box 230, Valrico, FL 33595
 Phone No.: 813.659.9197
 FBPE Registry No. 9813

PRODUCT:
 DUNBARTON REDIFLEX
 TWO-PIECE STEEL FRAME
 PART OR ASSEMBLY:
 BUCK AND FRAME ANCHORING
 MASONRY 2X BUCK

NO.	DATE	BY	REVISIONS
3	8/11/20	DAC	UPDATE TO 7TH ED. (2020) FBC
2	9/30/17	LFS	UPDATE TO 6TH ED. (2017) FBC
1	3/23/15	JK	UPDATE TO 5TH ED. (2014) FBC

DATE: 6/3/13
 SCALE: N.T.S.
 DWG. BY: JK
 CHK. BY: LFS
 DRAWING NO.: FL-15341.8
 SHEET 6 OF 9

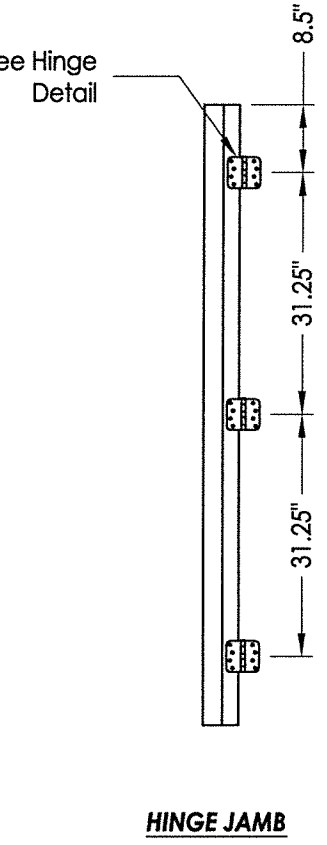
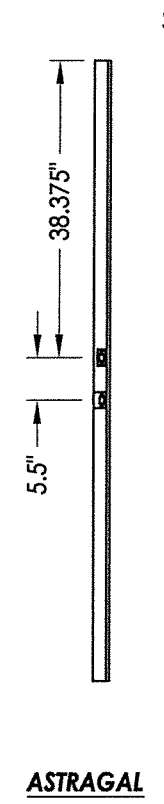
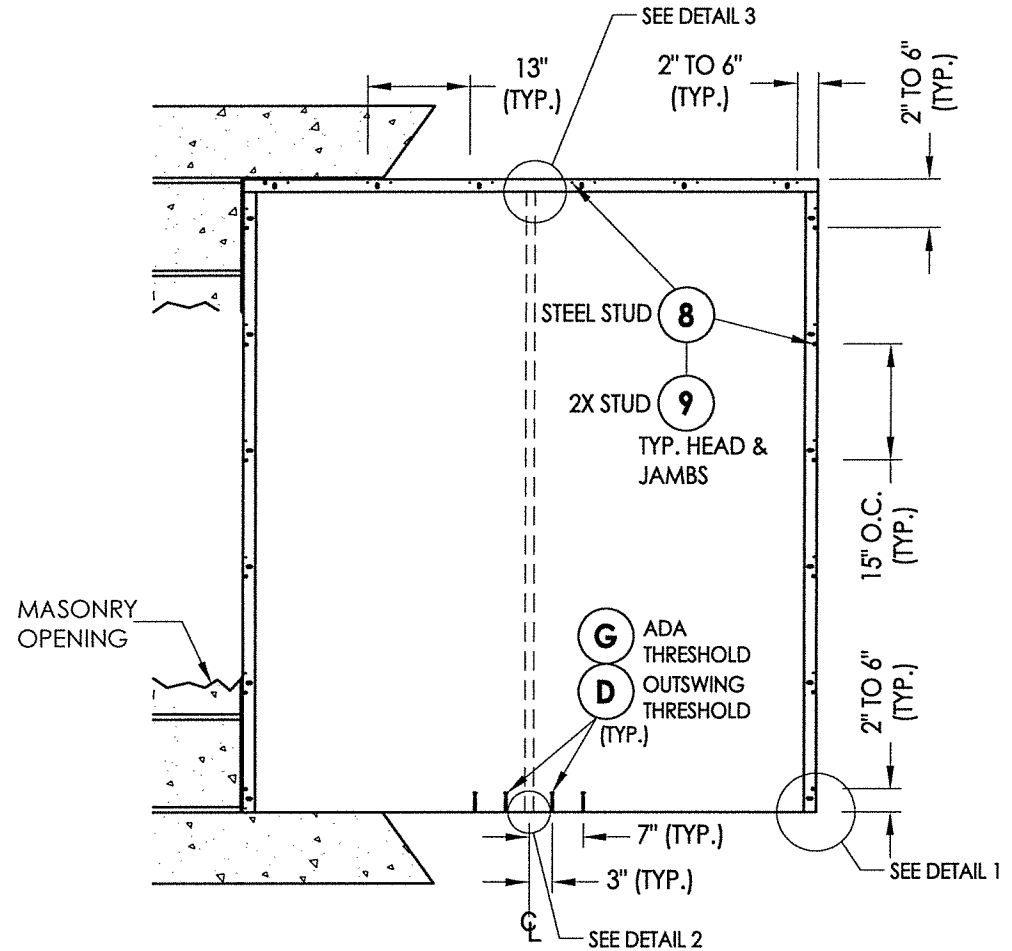
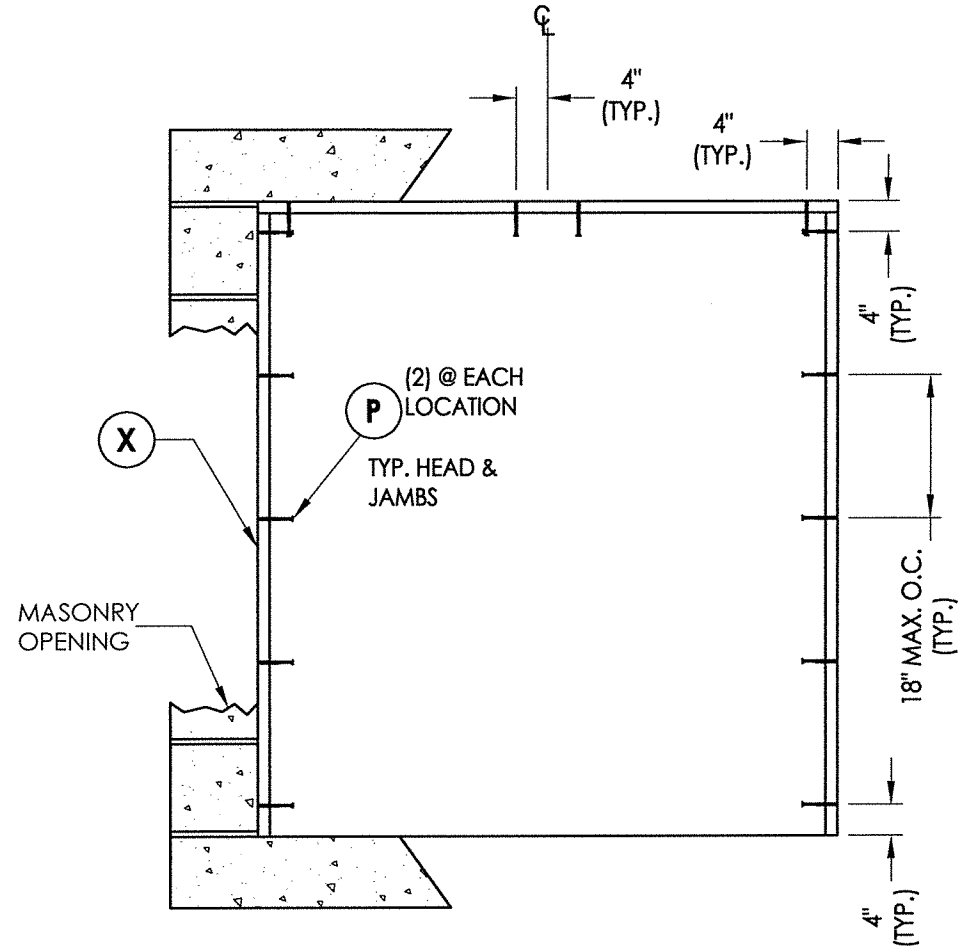

CONCRETE ANCHOR NOTES:

- Concrete anchor locations at the corners may be adjusted to maintain the min. edge distance to mortar joints.
- Concrete anchor locations noted as "MAX. ON CENTER" must be adjusted to maintain the min. edge distance to mortar joints, additional concrete anchors may be required to ensure the "MAX. ON CENTER" dimension are not exceeded.
- Concrete anchor table:

ANCHOR TYPE	ANCHOR SIZE	MIN. EMBEDMENT	MIN. CLEARANCE TO MASONRY EDGE	MIN. CLEARANCE TO ADJACENT ANCHOR
ITW TAPCON®	1/4"	1-1/4"	2"	4" / 3" (steel stud)
DeWALT ULTRACON+®	1/4"	1-1/4"	1"	4"

WOOD SCREW INSTALLATION NOTES:

- Maintain a minimum 5/8" edge distance, 1" end distance, & 1" o.c. spacing of wood screws to prevent the splitting of wood.

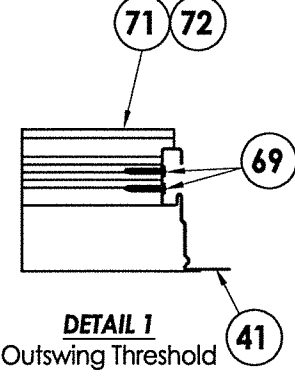
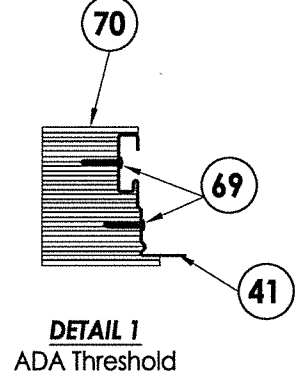
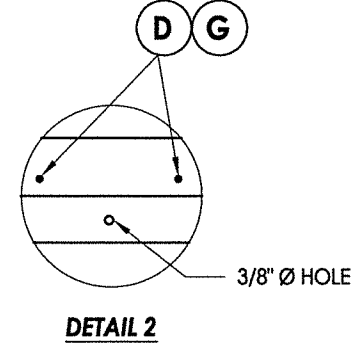
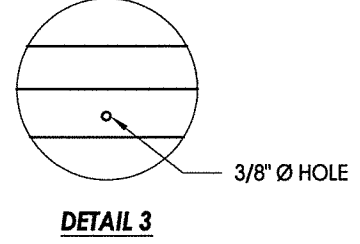
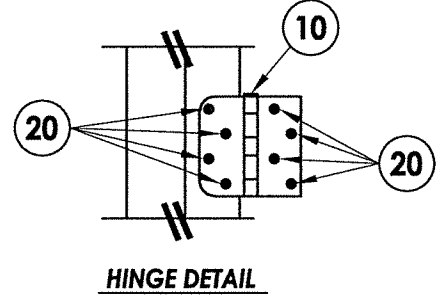
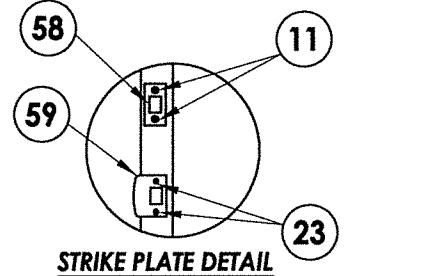

STATE OF FLORIDA
REGISTERED PROFESSIONAL ENGINEER
LYNDON F. SCHMIDT
No. 43409

August 11, 2020
Documents Prepared By:
Lyndon F. Schmidt
P.E. No. 43409

RW BUILDING CONSULTANTS, INC.
P.O. Box 230, Valrico, FL 33595
Phone No.: 813.659.9197
FBPE Registry No. 9813

PRODUCT:		DUNBARTON REDIFLEX TWO-PIECE STEEL FRAME	
PART OR ASSEMBLY:		BUCK & FRAME ANCHORING STEEL/2X STUD	
NO.	DATE	BY	REVISIONS
3	8/11/20	JBC	UPDATE TO 7TH ED. (2020)
2	9/30/17	FBC	UPDATE TO 6TH ED. (2017)
1	3/23/15	FBC	UPDATE TO 5TH ED. (2014)
DATE:		6/3/13	
SCALE:		N.T.S.	
DWG. BY:		JK	
CHK. BY:		LFS	
DRAWING NO.:		FL-15341.8	
SHEET		7 OF 9	

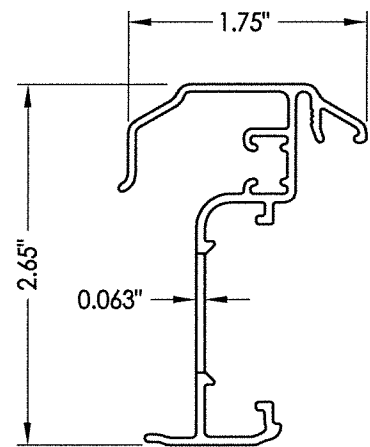
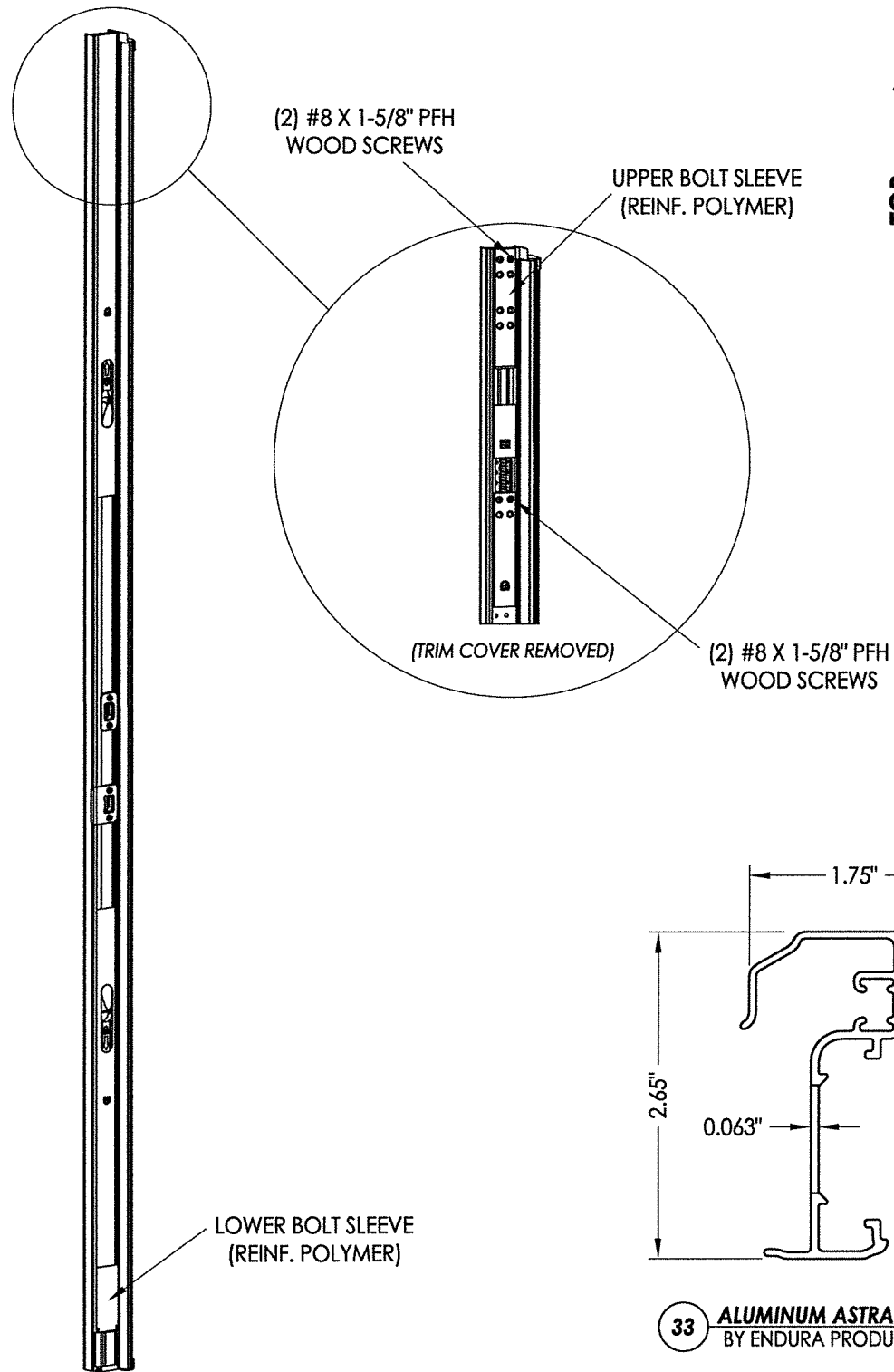

33 ALUMINUM ASTRAGAL BY ENDURA PRODUCTS

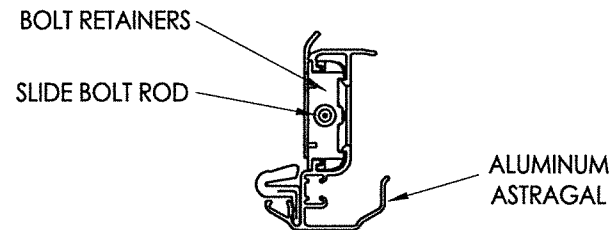
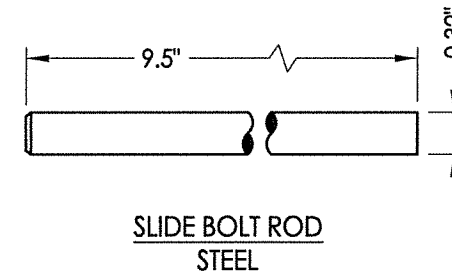
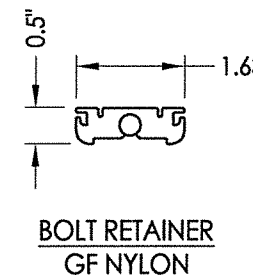
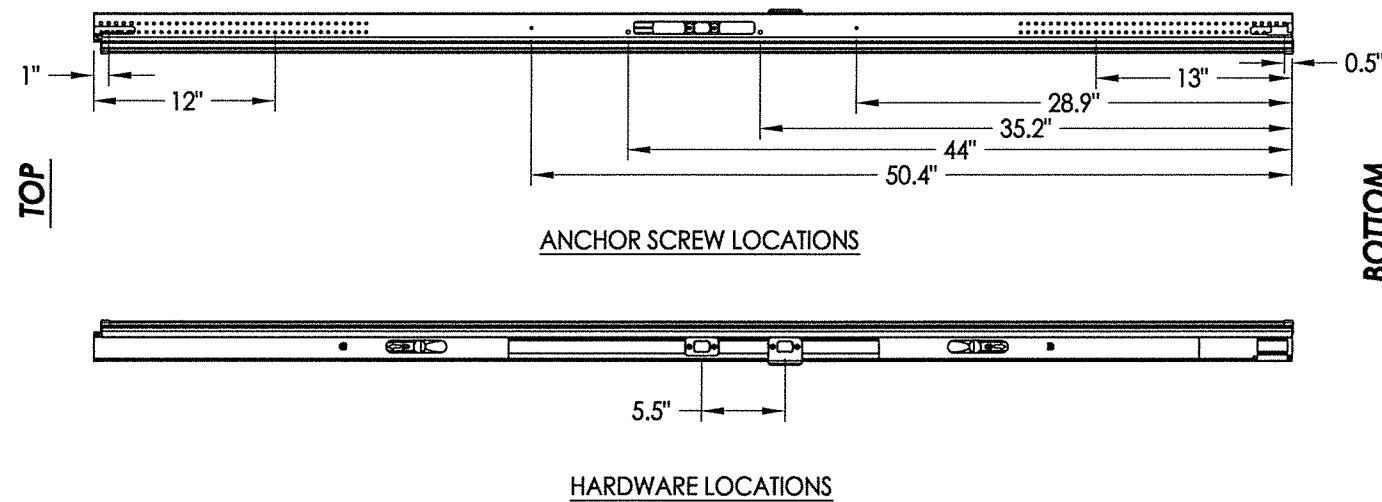

ALUMINUM ASTRAGAL ASSEMBLY

ULTIMATE HURRICANE ASTRAGAL

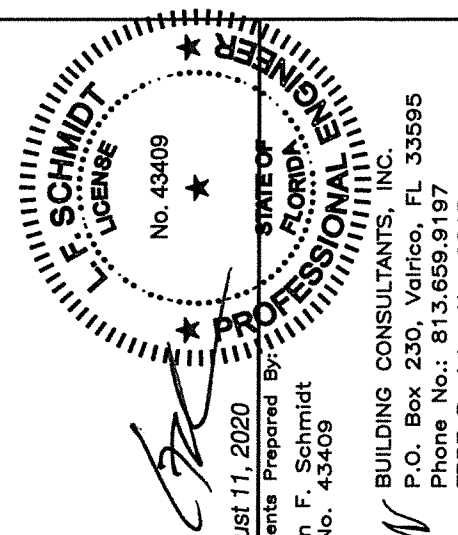

August 11, 2020

Documents Prepared By:
Lyndon F. Schmidt
P.E. No. 4-3409

R.W. BUILDING CONSULTANTS, INC.
P.O. Box 230, Valrico, FL 33595
Phone No.: 813.659.9197
FBPE Registry No. 9813

PRODUCT:
DUNBARTON REDIFLEX
TWO-PIECE STEEL FRAME

PART OR ASSEMBLY:
ASTRAGAL DETAILS

NO.	DATE	REVISIONS
3	8/11/20	UPDATE TO 7TH ED. (2020) FBC DAC
2	9/30/17	UPDATE TO 6TH ED. (2017) FBC LFS
1	3/23/15	UPDATE TO 5TH ED. (2014) FBC JK

DATE: 6/3/13

SCALE: N.T.S.

DWG. BY: JK

CHK. BY: LFS

DRAWING NO.:

FL-15341.8

SHEET 8 OF 9

\\dc01\rbw\clients\Dunbarton Permanent\A - Florida Product Approvals\FL-15341 - Exterior Door Components - Rediflex Steel Frames\C - Drawings\FL-15341 (2020)\FL-15341.5-8.dwg

BILL OF MATERIALS

ITEM #	DESCRIPTION	MATERIAL
A	2X FRAMING: SG >= 0.55	WOOD
B	2X BUCK SG >= 0.55	WOOD
E	MASONRY - 3,000 PSI MIN. CONCRETE CONFORMING TO ACI 301 OR HOLLOW BLOCK CONFORMING TO ASTM C90	CONCRETE
D	1/4" X 2-3/4" DeWALT OR ITW PFH CONCRETE SCREW	STEEL
G	1/4" X 2-1/4" DeWALT OR ITW PFH CONCRETE SCREW	STEEL
P	1/4" X 1-3/4" ITW HWH CONCRETE SCREW	STEEL
X	SSMA STUD 550S162-54 (Fy = 33 ksi, Fu = 45 ksi)	STEEL
8	10-16 TEKS SELF-DRILLING SCREW (ITW BUILDEX)	STEEL
9	#6 X 2" PFH WS (1-3/8" MIN. EMBEDMENT)	STEEL
10	HINGE	STEEL
11	#8 X 2-1/2" PPH SCREW	STEEL
14	#8 X 3/8" PFH WS	STEEL
20	10-24 X 1/2" PFH MS	STEEL
23	#6 X 1-1/2" PFH WOOD SCREW (1-3/8" MIN. EMBEDMENT)	STEEL
29	JAMB HINGE REIN. 14 GA. 4" x 4" x 1.53" (.075" GALV. STEEL) BY DUNBARTON FR00505	STEEL
30	COMPRESSION WEATHERSTRIPPING QLON QDS 650 BY SCHLEGEL	FOAM
33	ASTRAGAL (ENDURA)	ALUM
41	REDIFLEX JAMB BASE 18 GA. (.042" MIN. GALV. STEEL) BY DUNBARTON	STEEL
42	REDIFLEX JAMB CLOSURE 22 GA. (.026" MIN. GALV. STEEL) BY DUNBARTON	STEEL
50	STEEL DOOR PANEL - by JELD-WEN	-
58	STRIKE PLATE - DEADBOLT	STEEL
59	STRIKE PLATE - LATCHBOLT	STEEL
69	#8 X 1-1/4" PWH SMS	STEEL
70	ADA THRESHOLD	ALUM
71	OUTSWING THRESHOLD	ALUM
72	HIGH DAM OUTSWING THRESHOLD	ALUM
74	8-32 x 3/8" PFH MS	STEEL

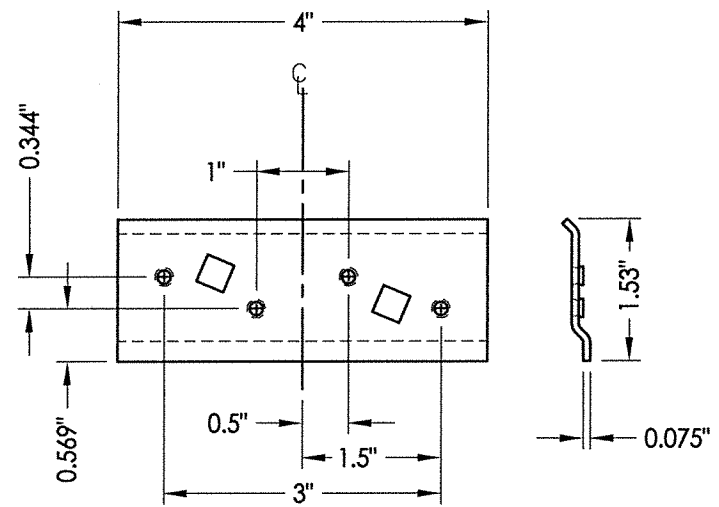

29 HINGE REINFORCEMENT

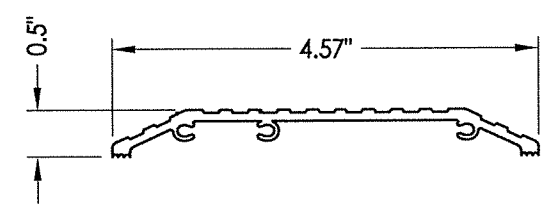

70 ADA THRESHOLD
Imperial

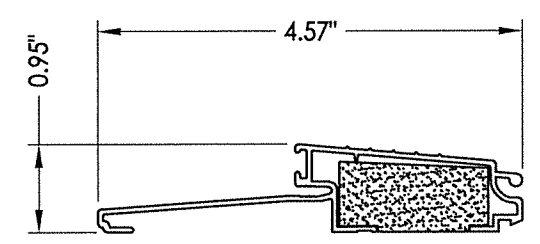

71 OUTSWING THRESHOLD
Imperial

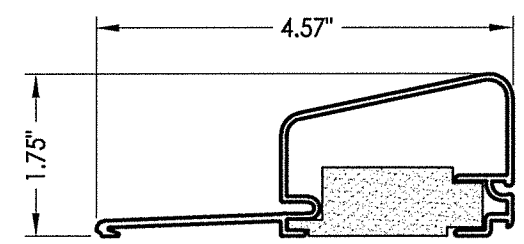

72 HIGH DAM THRESHOLD
AFCO

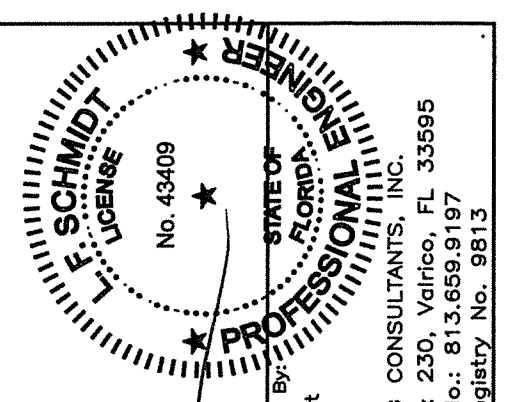

August 11, 2020
 Documents Prepared By:
 Lyndon F. Schmidt
 P.E. No. 43409
 R.W.
 BUILDING CONSULTANTS, INC.
 P.O. Box 230, Valrico, FL 33595
 Phone No.: 813.659.9197
 FBPE Registry No. 9813

PRODUCT:
 DUNBARTON REDIFLEX
 TWO-PIECE STEEL FRAME
 PART OR ASSEMBLY:
 BILL OF MATERIALS
 & COMPONENTS

NO.	DATE	REVISIONS
3	8/11/20	UPDATE TO 7TH ED. (2020) FBC DAC
2	9/30/17	UPDATE TO 6TH ED. (2017) FBC LFS
1	3/23/15	UPDATE TO 5TH ED. (2014) FBC JK
		BY

DATE: 6/3/13
 SCALE: N.T.S.
 DWG. BY: JK
 CHK. BY: LFS
 DRAWING NO.:
 FL-15341.8
 SHEET 9 OF 9